



- SELF-LOCKING
- SELF-CLINCHING
- FASTENERS

BULLETIN



LK₅₀₅

Revised 406

SELF-LOCKING SELF-CLINCHING FASTENERS

PEM® self-locking fasteners (Type LK/LKS/LKA) permanently retain their inherent flexing action, permitting repeated use and effective prevailing locking torque.

The unique PEMFLEX® self-locking feature with EF or MD finishes, meet the locking torque requirements for 250°F nuts of NASM25027 specification. The self-clinching feature is the same tried and proven design preferred and appreciated for fast, simple assembly. These fasteners do not protrude through the reverse side of the sheet and provide positive, permanent attachment with high torque-out (many times greater than locking torque) and pushout resistances.

PEM all-metal, self-locking fasteners are available in steel, stainless steel, and aluminum. Types LK (steel) and LKS (stainless) are treated with a black dry film lubricant for better locking performance. Type LKA (aluminum) must be used with a lubricated screw. The PEM design utilizes two rugged, semicircular flexing jaws instead of several less-supported segments. The greater ruggedness and retention of this PEMFLEX action prevents relaxation and loosening of the fastener in severe service.

This PEMFLEX design also protects the screw threads. Clearances obtained by only two interruptions of a full circumference, together with the spreading of the jaws by the entering screw, minimize the possibility of thread damage.

Screws for use with PEM self-locking fasteners should be Class 3A fit or no smaller than Class 2A (metric—Class 4h fit or no smaller than Class 6g) and long enough so that at least two threads project through PEMFLEX fasteners when tightened.

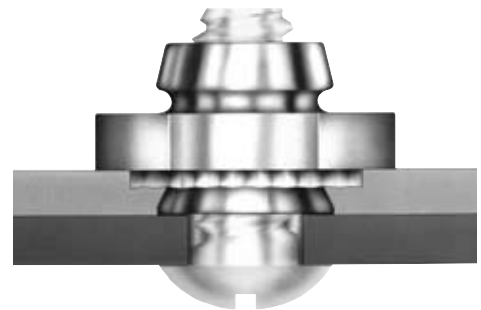

Part Number Designation

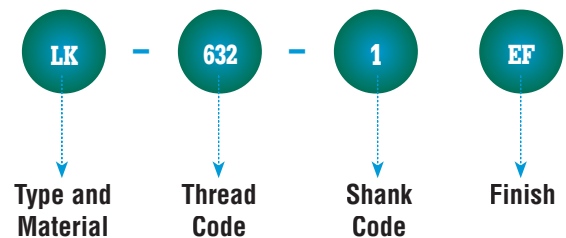

Groove indicates metric part

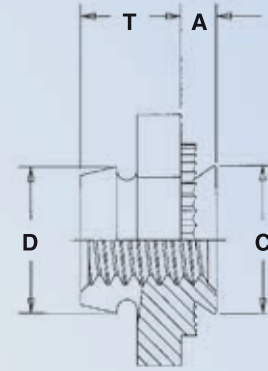
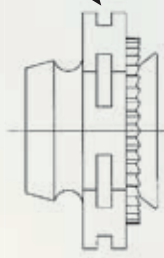

All dimensions are in inches.

UNIFIED	Thread Size	Type			Thread Code	Shank Code	A (Shank) Max.	Min. Sheet Thickness	Hole Size In Sheet +.003 -.000	C Max.	D Max.	E Nom.	T ± .010	Min. Dist. Hole C/L To Edge
		Fastener Material												
		Carbon Steel	Stainless Steel	Aluminum										
.086-56 (#2-56)	LK	LKS	LKA	256 ^{NS}	1	.038	.040	.172	.171	.165	.250	.135	.156	
					2	.054	.056							
.112-40 (#4-40)	LK	LKS	LKA	440	1	.038	.040	.187	.186	.185	.250	.135	.156	
					2	.054	.056							
.138-32 (#6-32)	LK	LKS	LKA	632	1	.038	.040	.219	.218	.220	.312	.145	.187	
					2	.054	.056							
.164-32 (#8-32)	LK	LKS	LKA	832	1	.038	.040	.266	.265	.250	.343	.175	.203	
					2	.054	.056							
.190-32 (#10-32)	LK	LKS	LKA ^{NS}	032	1 ^{NS}	.038	.040	.312	.311	.300	.375	.205	.218	
					2	.054	.056							

All dimensions are in millimeters.

METRIC	Thread Size x Pitch	Type			Thread Code	Shank Code	A (Shank) Max.	Min. Sheet Thickness	Hole Size In Sheet +0.08	C Max.	D Max.	E Nom.	T ± 0.25	Min. Dist. Hole C/L To Edge
		Fastener Material												
		Carbon Steel	Stainless Steel	Aluminum										
M2.5 X 0.45	LK	LKS	LKA	M2.5 ^{NS}	1	0.97	1	4.37	4.35	4.45	6.35	3.43	3.9	
					2	1.38	1.4							
M3 X 0.5	LK	LKS	LKA ^{NS}	M3	1	0.97	1	4.75	4.73	4.85	6.35	3.43	4	
					2	1.38	1.4							
M4 X 0.7	LK	LKS	LKA ^{NS}	M4	1	0.97	1	6.76	6.73	6.2	8.73	4.45	5.2	
					2	1.38	1.4							
M5 X 0.8	LK	LKS	LKA ^{NS}	M5	1 ^{NS}	0.97	1	7.92	7.9	7.75	9.53	5.21	5.6	
					2	1.38	1.4							

NS Not stocked. Available on special order only.

MATERIAL & FINISH SPECIFICATIONS

Type	Threads	Thread Locking Performance	Fastener Materials			Standard Finishes			Optional Finish	For Use In Sheet Hardness	
	Internal, ANSI B1.1, 3B/ANSI/ASME B1.13M, 6H	NASM25027 (as applicable)	Heat-treated Carbon Steel	300 Series Stainless Steel	7075-T6 Aluminum	Black, Dry-film Lubricant Over Zinc Phosphate (2)	Black Dry-film Lubricant (1)	Plain	Black Dry-film Lubricant Per MIL-PRF-46010 Over Cadmium Chromate Prime(1)	70 or Less on the Rockwell "B" Scale	50 or Less on the Rockwell "B" Scale
LK	•	•	•			•			•	•	
LKS	•	•		•			•		•	•	
LKA ⁽³⁾	•	•			•			•			•
Part number codes for finishes						MD ⁽⁴⁾	MD ⁽⁴⁾		EF ⁽⁴⁾		

(1) EF finish on steel and stainless steel and MD finish on stainless steel provides a minimum of 100 hours of salt spray resistance.

(2) MD finish on steel provides a minimum of 24 hours of salt spray resistance.

(3) Aluminum mating screws must be lubricated.

(4) Consult our Engineering department or check our web site for details on EF and MD finish specifications.

INSTALLATION

1. Punch or drill properly sized mounting hole in sheet. Do not perform any secondary operations such as deburring.
2. Insert fastener into the anvil hole and place the mounting hole over the shank of fastener as shown in drawing to the right.
3. With punch and anvil surfaces parallel, apply squeezing force until hexagonal flange contacts mounting sheet. Examples of installation forces are shown below. The sketch at the right indicates suggested tooling for applying these forces.

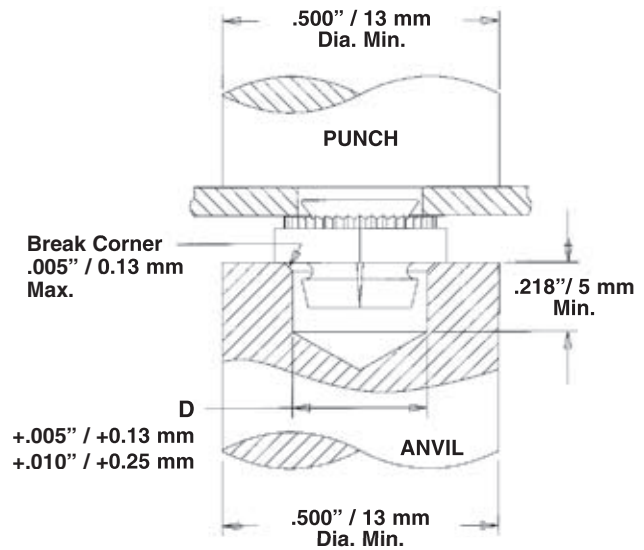

PEMSERTER® PRESSES

For best results we recommend using a PEMSERTER® press for either manual or automatic installation of PEM LK, LKS, and LKA fasteners. For more information on our line of presses call 1-800-523-5321, or check our website.

PERFORMANCE DATA⁽¹⁾

UNIFIED	Thread Code	Shank Code	Maximum Prevailing Torque In Locking Element (in. lbs.)	Test Sheet Material					
				5052-H34 Aluminum			Cold-rolled Steel		
				Installation (lbs.)	Pushout (lbs.)	Torque-out (in. lbs.)	Installation (lbs.)	Pushout (lbs.)	Torque-out (in. lbs.)
256	1	2.5	1600	130	20	3000	150	20	
	2		2000	150	30	3000	160	20	
440	1	5	1600	130	25	3000	150	30	
	2		2000	200	35	3000	250	40	
632	1	10	2400	130	25	4000	150	45	
	2		2700	225	45	4300	275	50	
832	1	15	2700	150	45	4000	190	50	
	2		3000	250	50	4300	300	70	
032	1	18	3200	150	90	4000	250	100	
	2		3200	250	105	4300	300	120	

METRIC	Thread Code	Shank Code	Maximum Prevailing Torque In Locking Element (N•m)	Test Sheet Material					
				5052-H34 Aluminum			Cold-rolled Steel		
				Installation (kN)	Pushout (N)	Torque-out (N•m)	Installation (kN)	Pushout (N)	Torque-out (N•m)
M2.5	1	0.45	7	578	2.8	13.5	665	3.4	
	2		9	890	3.9	13.5	1110	4.5	
M3	1	0.56	7	578	2.8	13.5	665	3.4	
	2		9	890	3.9	13.5	1110	4.5	
M4	1	1.7	12	665	5	18	845	5.6	
	2		12	1110	5.6	18	1330	7.9	
M5	1	2.05	12	665	10.1	18	1110	11.3	
	2		12	1110	11.8	19	1330	13.5	

(1) The installation, pushout and torque-out values reported are averages when all installation specifications and procedures are followed. Variations in mounting hole size, panel material and installation procedure will affect this data. Performance testing of this product in your application is recommended. We will be happy to provide samples for this purpose.

RoHS compliance information can be found on our website.

Specifications subject to change without notice. Check our website for the most current version of this bulletin.

PennEngineering®



North America: Danboro, PA 18916 USA • E-mail: info@pemnet.com • Tel: +1-215-766-8853 • Fax: +1-215-766-0143 • 800-237-4736 (USA Only)
 U.K. And Europe: Doncaster, England • E-mail: uk@pemnet.com Tel: +44 (0)1302 765700 • Fax: +44 (0)1302 367580
 Asia/Pacific: Singapore • E-mail: singapore@pemnet.com • Tel: +65-6-745-0660 • Fax: +65-6-745-2400
 Shanghai, China • E-mail: china@pemnet.com • Tel: +86-21-5868-3688 • Fax: +86-21-5868-3988

Visit our PEMNET™ Resource Center at www.pemnet.com

CAGE-46384